

Sonstige Gewindearten und Steigungen nach Kundenwunsch.
Die Innengewinde sind variabel.

x=Mögliche Kombination

Außengewinde (a)

| | | M16 x1,5 | M20 x1,5 | M24 x1,5 | M25 x1,5 | M26 x1,5 | M28 x1,5 | M30 x1,5 | M32 x1,5 | M33 x1,5 | M36 x1,5 | M38 x1,5 | M40 x1,5 | M42 x1,5 | M48 x1,5 | M50 x1,5 |
|------------------|---------|-------------|-------------|-------------|-------------|-------------|-------------|-------------|-------------|-------------|-------------|-------------|-------------|-------------|-------------|-------------|
| Innengewinde (b) | M10x1,5 | x | x | x | x | x | x | x | x | x | x | x | x | x | x | x |
| | M12x1,5 | | x | x | x | x | x | x | x | x | x | x | x | x | x | x |
| | M14x1,5 | | x | x | x | x | x | x | x | x | x | x | x | x | x | x |
| | M16x1,5 | | | x | x | x | x | x | x | x | x | x | x | x | x | x |
| | M20x1,5 | | | | | x | x | x | x | x | x | x | x | x | x | x |
| | M22x1,5 | | | | | | x | x | x | x | x | x | x | x | x | x |
| | M24x1,5 | | | | | | | x | x | x | x | x | x | x | x | x |
| | M25x1,5 | | | | | | | | x | x | x | x | x | x | x | x |
| | M26x1,5 | | | | | | | | | x | x | x | x | x | x | x |
| | M28x1,5 | | | | | | | | | | x | x | x | x | x | x |
| | M30x1,5 | | | | | | | | | | | x | x | x | x | x |
| | M32x1,5 | | | | | | | | | | | | x | x | x | x |
| | M33x1,5 | | | | | | | | | | | | | x | x | x |
| | M36x1,5 | | | | | | | | | | | | | x | x | x |
| M38x1,5 | | | | | | | | | | | | | | x | x | |
| M42x1,5 | | | | | | | | | | | | | | | x | x |

| | | | | | | | | |
|-------|----------|-------|------|--|----------|---------------------------------|---------------------------------|-----|
| | | | | Datum | Name | Werkstoff: CuZn39Pb3 F44 (Ms58) | | |
| | | | | Bearb. | 24.11.14 | Blokesz | Reduzierhülsen-Übersicht | |
| | | | | Gepr. | 24.11.14 | S.Dill | | |
| | | | | Norm | | | | |
| | | | | Emil A. Peters GmbH & Co. KG Westfalenstr. 85 D-58636 Iserlohn | | | Zeichnungsnummer | M - |
| | | | | | | | 29-97/36 | |
| Zust. | Anderung | Datum | Name | | | | | |

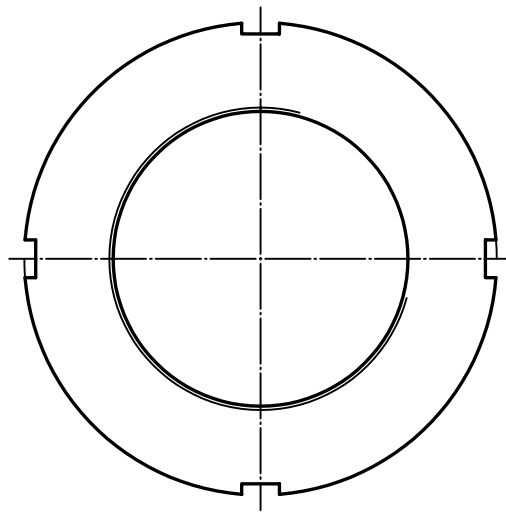
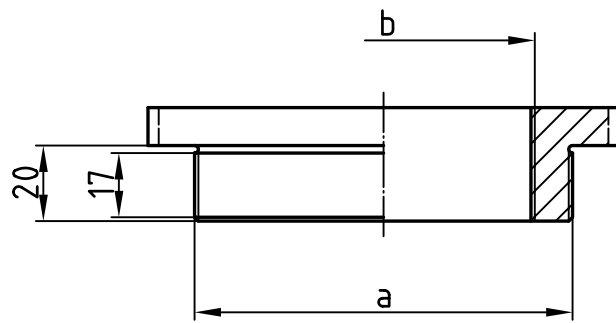

Sonstige Gewindearten und Steigungen nach Kundenwunsch.
Die Innengewinde sind variabel.

x=Mögliche Kombination

Außengewinde (a)

| | | M56x1,5 | M100x1,5 | | | | | | | | | | | |
|------------------|---------|---------|----------|--|--|--|--|--|--|--|--|--|--|--|
| | | | | | | | | | | | | | | |
| Innengewinde (b) | M20x1,5 | x | | | | | | | | | | | | |
| | M60x1,5 | | x | | | | | | | | | | | |
| | M80x1,5 | | x | | | | | | | | | | | |
| | | | | | | | | | | | | | | |
| | | | | | | | | | | | | | | |
| | | | | | | | | | | | | | | |
| | | | | | | | | | | | | | | |
| | | | | | | | | | | | | | | |
| | | | | | | | | | | | | | | |
| | | | | | | | | | | | | | | |

| | | | | | | | | | | | | | | |
|-------|----------|-------|------|--|----------|---------------------------------|---------------------------------|--|--|--|--|--|-----|--|
| | | | | Datum | Name | Werkstoff: CuZn39Pb3 F44 (Ms58) | | | | | | | | |
| | | | | Bearb. | 10.03.15 | Blokesz | Reduzierhülsen-Übersicht | | | | | | | |
| | | | | Gepr. | 10.03.15 | S.Dill | | | | | | | | |
| | | | | Norm | | | | | | | | | | |
| | | | | Emil A. Peters GmbH & Co. KG Westfalenstr. 85 D-58636 Iserlohn | | | Zeichnungsnummer | | | | | | M - | |
| | | | | | | | 29-97/36 | | | | | | | |
| Zust. | Anderung | Datum | Name | | | | | | | | | | | |